

ANDRITZ self-priming centrifugal pump

AD series

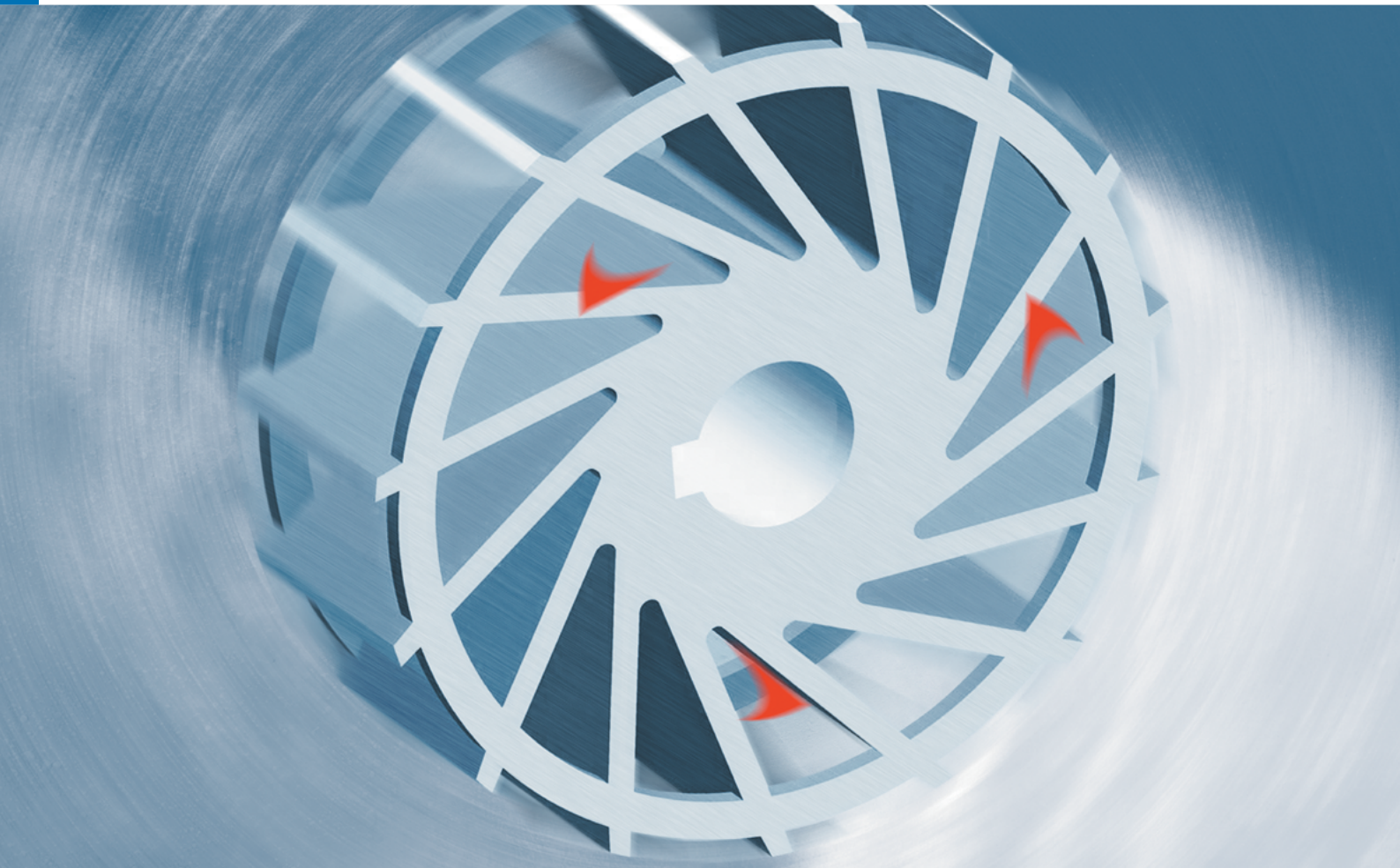

For media with high gas content

For over 100 years, ANDRITZ has been a byword for competence and innovation in designing centrifugal pumps.

ANDRITZ self-priming centrifugal pumps, AD series, are successfully in operation all over world. They offer robustness and wear resistance and thus fulfil high customer expectations regarding efficiency, life cycle, maintenance friendliness and economic efficiency.

All pump parts are manufactured according to the highest quality standards in our ISO certified workshops. The superior quality of our products derives from compliance with these stringent requirements.

Fields of application

- Sugar industry
- Pulp and paper industry
- Water supply and waste water treatment
- Food industry

Thanks to its semi-open impeller, the AD-series pump is very well suited for conveying viscous (e.g. sugar concentrations of up to 70%) and high-solids media (e.g. for pulp, paper or sewage applications).

Modular system

The standard components in ANDRITZ pumps provide high availability and enable the use of proven components.



The facts

- Flow rates up to 2,000 m³/h
- Heads up to 75 m
- System pressure up to 16 bar
- Temperatures up to 80°C

Technology to convince you

The high standard of ANDRITZ centrifugal pumps, AD series, is based on decades of experience in designing hydraulic machines and on extensive process know-how.

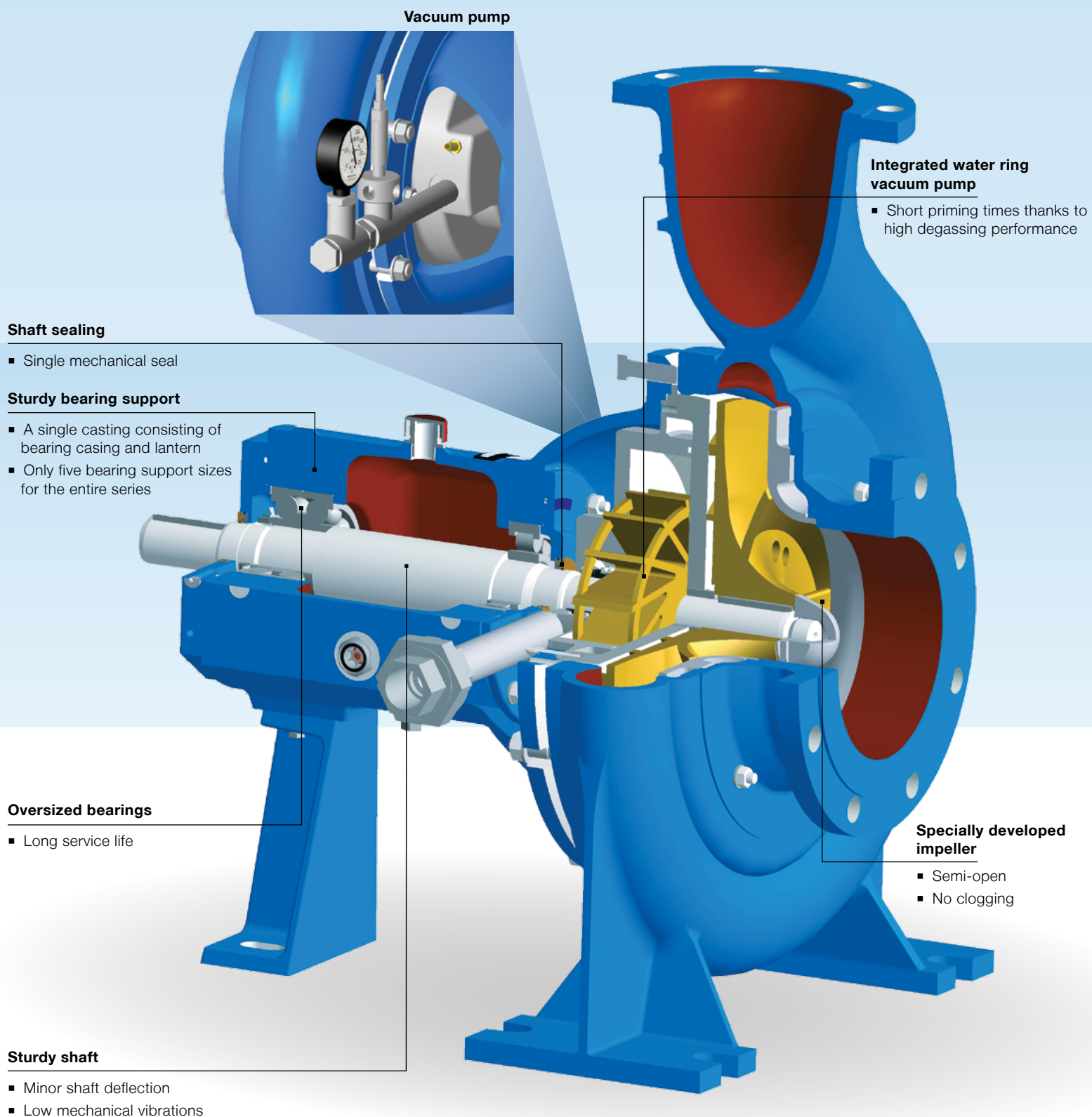

Vacuum pump

Integrated water ring vacuum pump

- Short priming times thanks to high degassing performance

Shaft sealing

- Single mechanical seal

Sturdy bearing support

- A single casting consisting of bearing casing and lantern
- Only five bearing support sizes for the entire series

Oversized bearings

- Long service life

Specially developed impeller

- Semi-open
- No clogging

Sturdy shaft

- Minor shaft deflection
- Low mechanical vibrations



High research and development capabilities

We run a pilot plant at our affiliate ASTRÖ, which enjoys international renown for its hydraulic developments and investigations. The high quality, safety and reliability of the AD pump series are ensured by extensive model testing.

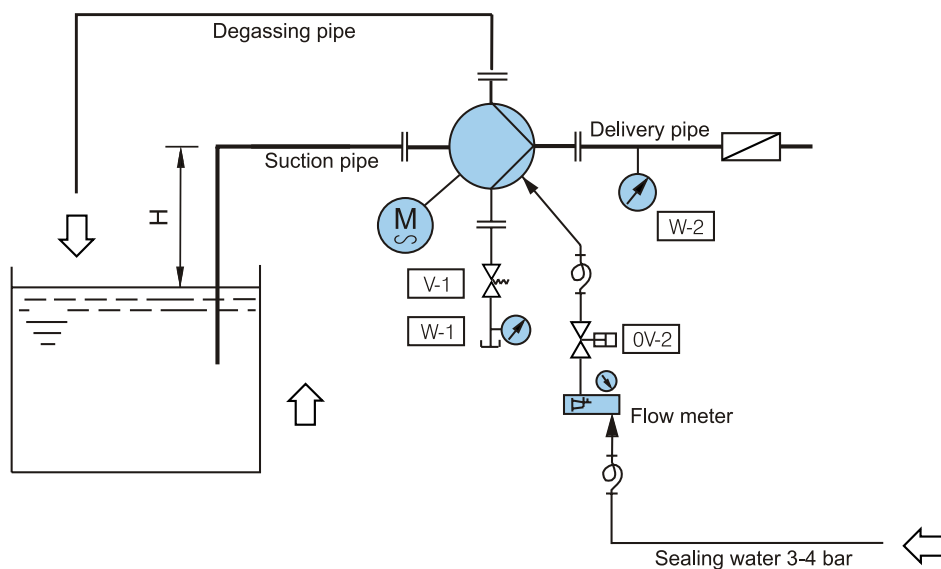

Characteristic curves

ANDRITZ self-priming centrifugal pumps

Characteristic curves 1500 rpm

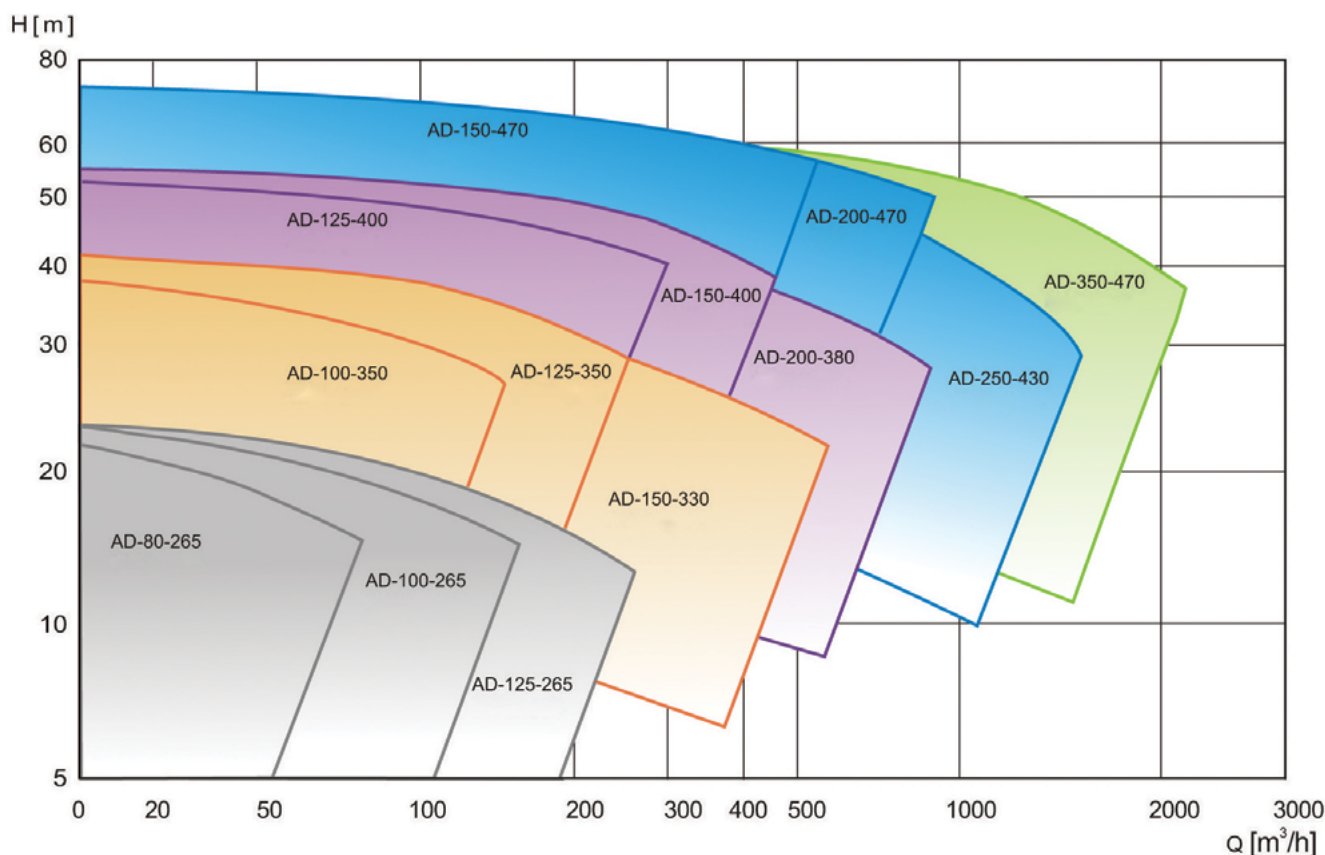

Material combinations

AD series	EN-GJL 250	1.4460	1.4462
Impeller		■	
Vacuum impeller		■	
Volute casing	■	■	
Bearing housing	■		
Front lining		■	
Casing cover		■	
Shaft			■

European standard		US standard	
Number	Name	Grade	UNS
EN-JL1040	EN-GJL 250	Class 40B	/
1.4460	X3CrNiMoN27-5-2	Grade 1A	J93370
1.4462	X2CrNiMoN22-5-3	S32205	S32205

Close to our customers

**ANDRITZ AG**

Stattegger Strasse 18
8045 Graz, Austria
Phone: +43 (316) 6902 0
Fax: +43 (316) 6902 413
pumps@andritz.com

www.andritz.com